

Predicting the hydraulic and life-cycle cost performance of rainwater harvesting systems using a computer based modelling tool

Roebuck, R.M., Ashley, R.M.

ABSTRACT

Rainwater harvesting systems are a recognised technique for reducing reliance on potable mains supply and as a potential way to save money. However, the widespread uptake of these systems has been slow partly due to the level of uncertainty surrounding hydraulic and financial performance. Current methods of assessment tend to be simplistic, using generalised rather than site-specific data. Often little account is taken of financial issues other than capital costs, such as operating/maintenance and decommissioning expenses.

To overcome these shortcomings, a computer based modelling tool called RainCycle© was developed that has the capability to perform more detailed analysis than is possible with existing methods. The program includes a detailed hydraulic model of a typical rainwater harvesting system and also has the ability to explicitly account for all major costs associated with these systems.

Modelling a number of proposed designs revealed that many of the current methods overestimate the hydraulic efficiency and potential cost savings that are achievable. However, it was found that water and monetary savings are still possible under favourable conditions. Further, it was found that capital, maintenance and required mains top-up water account for the majority of the whole life costs, whilst energy and decommissioning costs represent a small fraction of the required lifetime expenditure.

Keywords: rainwater harvesting, modelling, hydraulic assessment, whole life costs

INTRODUCTION

This paper describes the development of a computer based modelling and assessment tool for rainwater harvesting (RWH) systems intended for domestic, commercial, public or industrial buildings. In most developed countries the wide-spread introduction of centralised water supply systems has meant that the need for localised collection, storage and reuse of rainwater has been relatively minor. However, in recent years there has been a renewed enthusiasm for RWH techniques, partly due to greater public awareness of environmental issues and also because of the escalating economic costs of providing water via centralised supply systems.

It was against this background that the first author, working with a UK Local Authority (LA), was attempting to incorporate RWH in a number of new-build school facilities. However, the LA was not satisfied with the publicly available means of assessing performance and judged that they were too simplistic and did not take enough account of Whole Life Cost (WLC) issues, such as operating/maintenance costs. A decision was made to create a new modelling tool that would explicitly address the shortcomings of the existing techniques and be able to provide the required level of detailed analysis. The title of this program is RainCycle©, a powerful but easy to use spreadsheet (Excel) based mass-balance transfer model for predicting the future hydraulic and financial performance of RWH systems.

REVIEW OF EXISTING WORK

Many examples of the existing computer-based assessment methods for RWH were found to be using the same underlying principle of mass-balance transfer as shown in figure 1.

Figure 1: Typical mass-balance transfer model

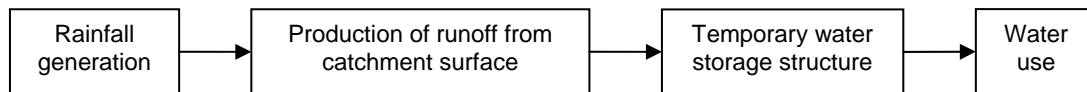

Most of the models found were very simplistic and consisted predominantly of Excel spreadsheets containing algorithms that replicated the processes shown in figure 1 and little else. These were often available over the Internet and were associated with RWH system suppliers, water conservation enthusiasts, sustainable development interest sites and so forth. A number of the more scientific/academic examples were found and these are summarised in table 1.

A review of current UK best practice methods was also undertaken. The most relevant information was found in the Construction Industry Research & Information Association (CIRIA) best practice manuals (Leggett *et al*, 2001a; Leggett *et al*, 2001b; Shaffer, 2004).

The literature review showed that, although some variation exists between individual models, there is widespread use of the mass-balance transfer principle (see figure 1) when predicting hydraulic performance.

Table 1: Selection of existing computer based hydraulic models for RWH

Reference	Description
Jenkins <i>et al</i> (1978)	An early behavioural model identifying two fundamental algorithms that describe the operation of a rainwater storage structure: Yield After Storage (YAS) and Yield Before Storage (YBS). Jenkins <i>et al</i> used the YAS algorithm and a monthly time interval to investigate the performance of rainwater storage in North America.
Dixon (1999)	Model of a domestic rainwater harvesting (DRWH) system for predicting water quality and water saving efficiency. Also includes some stochastic elements for creating water demand profiles and a basic whole life costing element.
Fewkes (1999); Fewkes and Butler (1999); Fewkes and Warm (2001)	Fewkes developed a number of models based on the YAS method described by Jenkins <i>et al</i> (1978). Fewkes and Warm (2001) describe a method of modelling RWH systems at eleven different locations in the UK. Recorded daily rainfall statistics and a daily time step were used to predict water saving efficiencies.
Day (2002); Ratcliffe (2002)	Rainwater harvesting project led by Telford and Wrekin Council, UK. Monitoring of DRWH system water usage and water quality was conducted. Water consumption data was used to build a model of the system.
Cobley (2004)	Describes a simple method for estimating the largest storage requirement based on the consumption rates and occupancy of a building. Similar in many aspects to the numerous basic models available from the Internet.

Note: all the models described in table 1 are based on mass-balance transfer algorithms

Whole Life Costing techniques

Whole Life Costing (WLC) methods applicable to the field of study were also investigated. No publications were found that dealt specifically with RWH although some literature was obtained that covered the more general aspects of predicting WLCs for sustainable drainage infrastructure (Woods-Ballard and Malcolm, 2003; HR Wallingford, 2004a, b).

The best practice guidance reviewed (Leggett *et al*, 2001a; Leggett *et al*, 2001b; Shaffer, 2004) did frequently mention cost issues and contained some examples, although these consisted of generalised data obtained from a small number of case studies and it is not known how applicable the information is to other sites. Advice was given on how to perform a cost-benefit analysis and this was taken into account when constructing the new model.

Examples of WLC models were fewer in number than the purely hydraulic variants. Again there were numerous basic examples available on the Internet and these generally employed a method of simply estimating the amount of mains water that could be substituted by harvested water and, knowing the cost of mains water; calculating how much money was saved. No account was taken of capital, operating/maintenance or decommissioning costs. Dixon (1999) included a cost algorithm in a model for DRWH systems that predicted cost savings and system pay-back period time, based on capital and running costs, where running costs consisted of the expense of operating the water pump and an aerator (no account was taken of maintenance costs). The model was created primarily for domestic systems and its applicability outside this area is not known.

THE RAINCYCLE© RAINWATER HARVESTING MODELLING TOOL

RainCycle©: aims and objectives

The review of existing computer based modelling tools revealed a wide variety of programs with varying levels of complexity and scope. It was decided that the RainCycle© model would be based on the YAS model as described by Jenkins *et al* (1978) since this is an accepted and widely used methodology. Hydraulic and whole life cost performance would be modelled in detail, but not water quality (or at least not explicitly).

Overview of main features

The following list highlights the main features of the modelling tool:

- Daily simulation of proposed design for up to 100 years of operation
- Compares the WLC of a RWH system with that of an equivalent mains-only system
- Takes explicit account of all associated costs, including capital (to-build), operating/maintenance and decommissioning costs
- Multiple values allowed on 11 key parameters which enables performance under a range of conditions to be investigated. Sensitivity analysis and Monte Carlo simulation also available
- Main results are output as: long-term savings, average yearly savings, pay-back period and percentage of demand met by harvested water
- Uses standard accounting techniques to calculate the Net Present Value (NPV)

Hydraulic model components

Figure 1 demonstrates the main components of the hydraulic model

Figure 1: Schematic representation of the RWH hydraulic model

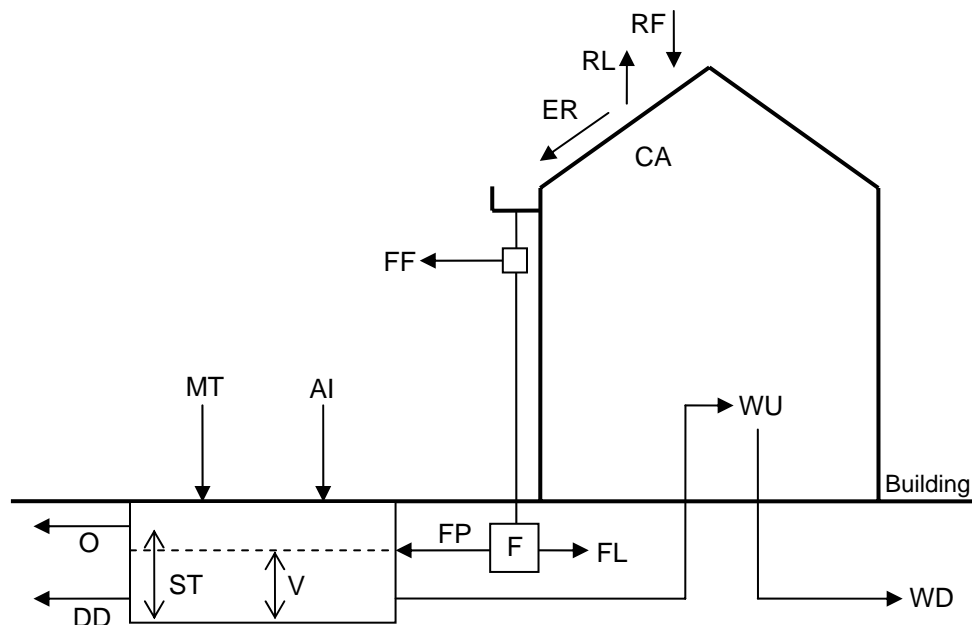

Key:

CA = catchment plan area (m^2)

RF = rainfall (mm/day)

RL = runoff losses (m^3/day)

ER = effective runoff (m^3/day)

FF = first-flush losses (m^3/day)

F = primary rainwater filter

FL = filter losses (m^3/day)

FP = filter pass forward flow (m^3/day)

ST = storage tank (m^3)

V = volume in tank (m^3/day)

MT = mains top-up (m^3/day)

AI = additional inputs, if any (m^3/day)

O = overflow from storage tank (m^3/day)

DD = drain-down volume (m^3/day)

WU = water usage (m^3/day)

WD = water disposal (m^3/day)

Financial model components

Figures 2 and 3 demonstrate the main components of the financial model, both for the mains-only system and the modelled RWH system

Figure 2: Schematic representation of mains-only financial model

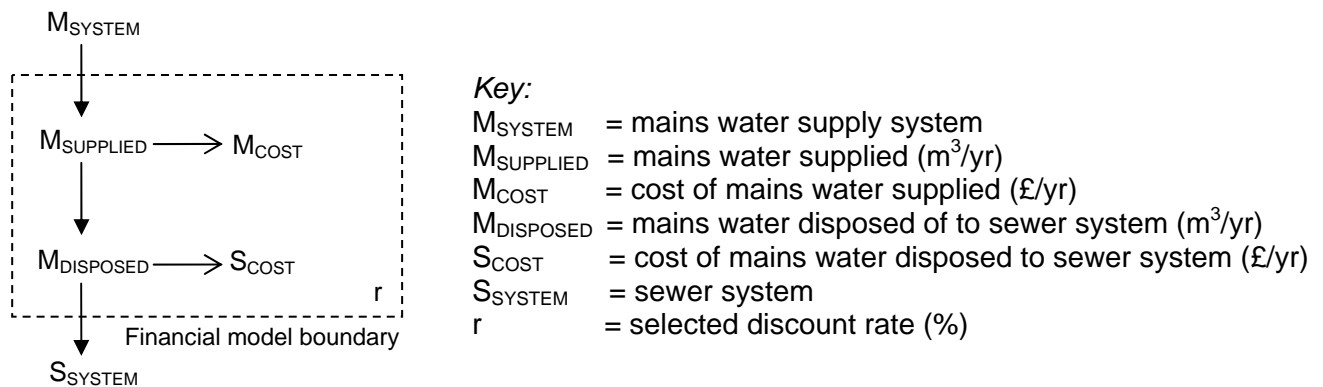
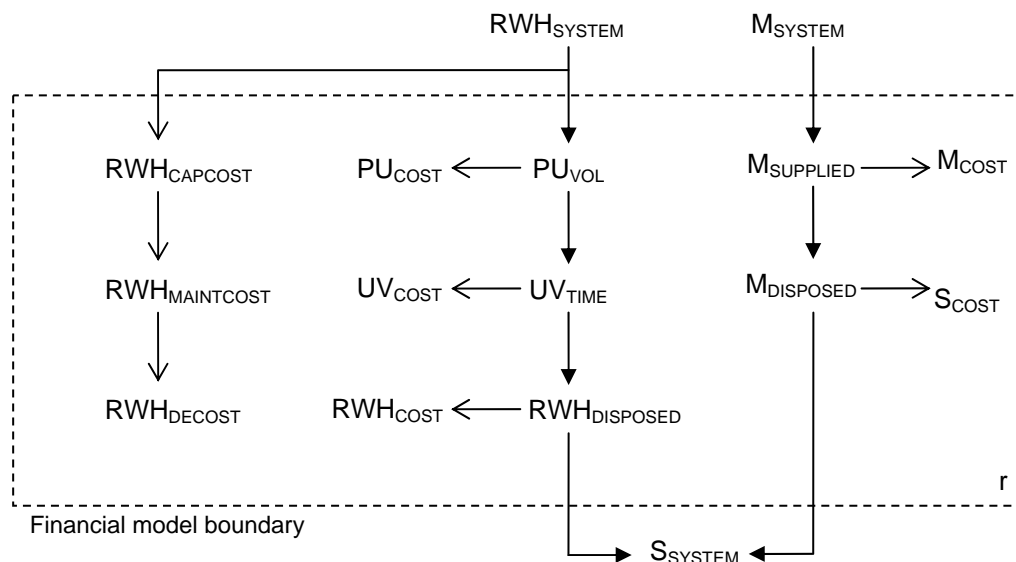

Figure 3: Schematic representation of the RWH financial model



Key:
 RWH_{SYSTEM} = rainwater harvesting system
 $RWH_{CAPCOST}$ = system capital cost (£)
 $RWH_{MAINTCOST}$ = maintenance cost (£/yr)
 $RWH_{DECCOST}$ = decommissioning cost (£)
 PU_{VOL} = volume pumped from tank (m^3/yr)
 PU_{COST} = cost to pump volume PU_{VOL} (£/yr)
 UV_{TIME} = operating time of UV unit (hrs/yr)
 UV_{COST} = operating cost of UV_{TIME} (£/yr)
 $RWH_{DISPOSED}$ = water to sewer system (m^3/yr)
 RWH_{COST} = cost of $RWH_{DISPOSED}$ (£/yr)
 M_{SYSTEM} = mains supply system
 $M_{SUPPLIED}$ = mains water supplied (m^3/yr)
 M_{COST} = cost of mains water supplied (£/yr)
 $M_{DISPOSED}$ = mains water disposed (m^3/yr)
 S_{COST} = cost of mains water disposed (£/yr)
 S_{SYSTEM} = sewer system
 r = selected discount rate (%)

Hydraulic model validation

Model validation was conducted by comparing the hydraulic outputs of RainCycle© against a methodology described by Fewkes and Warm, (2001). The comparison showed that, for each system assessed, both methods gave similar results when predicting the percentage of demand met for a range of tank sizes. Results from the RainCycle© model were generally within agreement of Fewke's by +/-10%, with an overall average difference of 5.5%.

RAINCYCLE© CASE STUDY

One of the previously mentioned RWH systems designed for the UK LA was analysed using RainCycle© and the results compared with the system supplier's own assessment to see how the two methods compared with regards to hydraulic and WLC performance.

High View Junior school case study

High View Junior school (fictitious name) is a design-and-build project intended to provide educational facilities for 680 pupils (340 male and 340 female). A proprietary RWH system has been proposed for the scheme with the aim of reducing mains water demand for urinal and W.C. flushing. The supplier also offers a yearly maintenance contract. Tables 2-4 show the data required by RainCycle© in order to be able to carry out an assessment. The expected operational life of the school is at least 65 years and so this was used as the time frame for the analysis.

Table 2: hydraulic details

Parameter	Probable value
Rainfall profile	886mm/yr
Catchment area	1,845 m ²
Runoff coefficient	0.85
Filter coefficient	0.90
Storage tank volume	45 m ³
Pump power rating	1.0 kW
Pumping capacity	60 l/min
UV unit power rating	55 W
Water demand	1,546 m ³ /yr

Table 3: financial details

Parameter	Probable value
Capital cost	£18,700
Decom. cost	£1,500
Discount rate	3.5 %
Electricity cost	5.5 p/kWhr
Mains water cost	£1.92/m ²

Table 4: maintenance schedule and associated costs

Item	Probable frequency	Probable cost
Maintenance contract	1 year	£250
Replace UV lamp	6 months	£65
Replace UV filter media	6 months	£60
Clean catchment surface	1 year	£100

RESULTS AND DISCUSSION

Model outputs and comparison with existing methodology

Table 5 shows the results obtained from RainCycle© when modelling the *expected* scenario. That is, with all parameters assigned their most probable values. The results from the supplier's own analysis are also provided in order to facilitate a comparison between the two methods.

Table 5: Predicted RWH system performance

Criteria	Supplier's prediction	RainCycle© prediction
Long-term savings*	£122,330**	£18,370***
Pay-back period	10 years	17 years
% demand met by harvested water	81%	69%
Average yearly savings	£1,882**	£283***

*Analysis period was 65 years **Zero discount rate applied ***3.5% discount rate applied

The results obtained using the new model were markedly different from those in the initial report provided by the supplier. Most noticeably, the expected long-term savings predicted by RainCycle© are significantly less (£18,370 over 65 years as opposed to £122,230). This is in part due to the fact that the hydraulic performance is less optimistic than the supplier's own estimate (69% of demand met by harvested rainwater as opposed to 81%) but more important was the fact that no discount rate was applied with the alternative method. Running the new model again with a zero discount

rate resulted in predicted long-term savings of £71,441, a significantly greater amount than when using a discount rate of 3.5%. It should be noted that applying a discount rate is considered proper when performing this type of long-term financial forecast and that it is a shortcoming of the alternative method not to take it into account. Likewise, the average yearly savings are also noticeably less (£283/yr as opposed to £1,882/yr). The estimated pay-back period (break-even point) was affected by the differences in financial assessment. The original analysis reported a pay-back period of 10 years whilst RainCycle© predicted 17 years.

The amount of water supplied to the end users was less in the RainCycle© model, despite demand being approximately the same in both methods. It is likely that this is due to the supplier's method assuming an unlimited storage capacity, i.e. that no overflows occurred from the storage tank and so all rainwater entering the tank is available for use, which is clearly unrealistic.

Detailed breakdown of long-term costs

A detailed breakdown of long-term costs is presented in table 6.

Table 6: Detailed breakdown of long-term costs

Cost item	Cost (£)	As % of WLC
Capital	18,700	31.1%
Maintenance	15,847	26.4%
Decommissioning	165	0.3%
Pump operating	431	0.7%
UV unit operation	700	1.2%
Mains top-up	24,220	40.3%
Total WLC of RWH system	60,064	-
<i>WLC of equivalent mains-only</i>	<i>78,434</i>	
RWH system savings	18,370	

Table 6 Notes

Discount rate of 3.5% was applied to costs. Analysis time = 65 years

The literature review revealed a general assumption that ongoing maintenance costs could form a significant fraction of the total WLCs. The analysis performed here appears to bear this out, with maintenance costs coming to a total of £15,847 over 65 years out of a total WLC of £60,064. This represents 26.4% of the total expenditure. Capital costs also contributed significantly: £18,700 out of a total of £60,064, or 31.1% of the total expenditure. The largest contribution was from the necessary mains top-up which cost £24,220, or 40.3% of the total cost.

The remaining costs combined only accounted for £1,296, or 2.2% of the WLC. Decommissioning came to £165 (0.3%) even though the input value was £1,500 because a discount rate of 3.5% per year was applied for 65 years, considerably reducing the Present Value (PV). Operating (electricity) costs for the pump and UV unit were £431 (0.7%) and £700 (1.2%) respectively. Note that these are the operating overheads only and do not include any maintenance that these components might require as this was taken into account elsewhere.

CONCLUSIONS

The hydraulic and whole life cost performance of rainwater harvesting systems has been investigated using a computer based modelling tool. Case study results for a UK school indicated that both water and monetary savings are possible in the long-term. However, the current methodologies used by many RWH system suppliers to predict future performance appear to be inadequate in both scope and detail, overestimating the amount of demand that can be met by harvested rainwater and also the level of financial savings achievable. This is mainly due to the use of models that oversimplify the hydraulic processes involved and financial techniques that take little account, if any, of system-specific requirements and do not use any discounting methods to calculate the true NPV.

Using the RainCycle© tool to model a proposed school system in detail and taking into account all associated cost items revealed a less optimistic, but more realistic, set of results. Although the results were less favourable, they still indicated that RWH is a viable way to reduce reliance on mains water and is also capable of saving money in the long-term under favourable conditions and in any case could reduce downstream impacts on the drainage system.

A detailed breakdown of the costs incurred by the system over its operational lifetime revealed that capital, maintenance and mains top-up accounted for the majority of the required expenditure, with a combined total of just under 98% of the WLCs. Pump and UV operating expenses, as well as decommissioning costs, accounted for significantly less with a combined expenditure of just over 2% of the WLCs.

REFERENCES

- Cobley J C. (2004). *SUDS: the consultant's specification*. Proc. of Standing Conference on Stormwater Source Control Quantity and Quality. 20th February 2004, Coventry university, UK, volume 25.
- Day M. (2002). *The Millennium Green development rainwater project*. Proc. of Standing Conference on Stormwater Source Control Quantity and Quality. 13th February 2002, Coventry university, UK, volume 22.
- Dixon A. (1999). *Simulation of domestic water reuse systems: greywater and rainwater in combination*. PhD thesis. Environmental and Water Resources Engineering, Department of Civil and Environmental Engineering, Imperial College of Science, Technology and Medicine, London, UK.
- Fewkes A. (1999). *Modelling the performance of rainwater collection systems. Towards a generalised approach*. Submitted to Urban Water
- Fewkes A. and Butler D. (1999). *Simulating the performance of rainwater collection systems using behavioural models*. Submitted to Building Services Engineering Research Technology.
- Fewkes A. and Warm P. (2001). *A method of modelling the performance of rainwater collection systems in the UK*. Proc. of 1st Nat. Conf. on Sustainable Drainage. 18-19th June 2001, Coventry university, UK, pp 232-242
- HR Wallingford (2004). *The operation and maintenance of sustainable drainage systems (and associated costs)*. Report SR626. HR Wallingford Ltd, Oxon, UK.
- HR Wallingford (2004). *Whole life costing for sustainable drainage*. Report SR627. HR Wallingford Ltd, Oxon, UK.
- Jenkins D., Pearson F., Moore E., Sun K. and Valentine R. (1978). *Feasibility of rainwater collection systems in California*. Contribution No. 173 Californian Water Resources Centre, University of California
- Leggett D J., Brown R., Brewer D., Stanfield G and Holliday E. (2001). *Rainwater and greywater use in buildings: best practice guidance*. CIRIA report C539. Construction Information & Research Information Association, London, UK.
- Leggett D., Brown R., Stanfield G., Brewer D. and Holliday E. (2001). *Rainwater and greywater use in buildings: decision-making for water conservation*. CIRIA report PR080. Construction Information & Research Information Association, London, UK
- Ratcliffe J. (2002). *Telford rainwater harvesting project*. Proc. of Standing Conference on Stormwater Source Control Quantity and Quality. 13th February 2002, Coventry university, UK, volume 22.
- Shaffer P., Elliot C., Reed J., Holmes J. and Ward M. (2004). *Model agreements for rainwater and greywater use systems*. CIRIA report C626. Construction Information & Research Information Association, London, UK.
- Woods-Ballard B. and Malcolm M. (2003). *Whole Life Costing for Sustainable Drainage Schemes*. Proc. of 2nd Nat. Conf. on Sustainable Drainage. 23rd-24th June 2003, Coventry university, UK, pp 181-192.